

DIESEL GENERATOR SET

AIR CHARGE-AIR COOLING

275 kVA / 50 Hz / Prime (Exhaust-Optimized)
380 - 415V

(Reference DS300D5S-Fuel Optimized for Standby Rating Technical Data)

BENEFITS

- // Low installment cost
- // Best fuel consumption values
- // Long maintenance intervals
- // High-efficiency components
- // Best-in-class reliability and availability



SYSTEM RATINGS*

Prime**	DP275D5S	DP275D5S	DP275D5S
Voltage (L-L)	380V	400V	415V
Phase	3	3	3
PF	0.8	0.8	0.8
Hz	50	50	50
kW	220	220	220
kVA	275	275	275
AMPS	418	397	383
skVA@30%			
Voltage Dip	590	650	700
Generator Model	433CSL6216	433CSL6216	433CSL6216
Temp Rise	125 °C/40 °C	125 °C/40 °C	125 °C/40 °C
Connection	12 LEAD HI WYE	12 LEAD HI WYE	12 LEAD HI WYE

* Power available up to 40°C / 400 m

** Prime technical data is for an Exhaust-Optimized Prime unit

CERTIFICATIONS AND STANDARDS

// **Engine-generator set is designed and manufactured in facilities certified to standards ISO 9001:2008 and ISO 14001:2004**

// **Performance Assurance Certification (PAC)**

- Engine-generator set tested to ISO 8528-5 for transient response
- Verified product design, quality and performance integrity
- All engine systems are prototype and factory tested

// **Power Rating**

Permissible average power output during 24 hours of operation is approved up to 75%.

STANDARD FEATURES*

- // The generator set complies to G2
- // Engine-generator set tested to ISO 8528-5 for transient response
- // Accepts rated load in one step per NFPA 110
- // All engine-generator sets are prototype and factory tested
- // MTU Onsite Energy is a single source supplier
- // Global Product Support
- // 2 Year Standard Warranty
- // 6R1600 Diesel Engine
 - 10.5 Liter Displacement
 - Common Rail Fuel Injection
 - 4-Cycle
- // Engine-generator resilient mounted
- // Complete Range of Accessories
- // Permanent Magnet Generator (PMG)
 - Brushless, Rotating Field Generator
 - 300% Short Circuit Capability
 - 2/3 Pitch Windings
- // Cooling System 50° C
 - Integral Set-Mounted
 - Engine Driven Fan
- // Terminal Box

STANDARD EQUIPMENT*

// Engine

.....
 Air Cleaner
 Oil Pump
 Oil Drain Extension & S/O Valve
 Full Flow Oil Filters
 Closed Crankcase Ventilation
 Jacket Water Pump
 Thermostat
 Exhaust Manifold - Dry
 Blower Fan & Fan Drive
 Radiator - Unit Mounted
 Electric Starting Motor - 24V
 Governor – Electronic Isochronous
 Base - Formed Steel
 SAE Flywheel & Bell Housing
 Charging Alternator - 24V
 Flexible Fuel Connectors
 TA-Luft Compliant Engine
 Fuel System: Common Rail

// Customer Interface

.....
 Smart Connect

// Generator

.....
 NEMA MG1, IEEE and ANSI standards compliance for temperature rise and motor starting
 VDE 0530, IEC 34.1, BS5000, CSA C22.2-100 und AS1359
 Sustained short circuit current of up to 300% of the rated current for up to 10 seconds
 Self-Ventilated and Drip-Proof
 Superior Voltage Waveform
 Digital, Solid State, Volts-per-Hertz Regulator
 No Load to Full Load Regulation
 Brushless Alternator with Brushless Pilot Exciter
 4 Pole, Rotating Field
 125 °C Prime Temperature Rise
 1 Bearing, Sealed
 Flexible Coupling
 Full Amortisseur Windings
 125% Rotor Balancing
 3-Phase Voltage Sensing
 ± 1% Voltage Regulation
 100% of Rated Load - One Step
 3% Maximum Harmonic Content
 Insulation Class H
 Protection Class IP20

* Represents standard product only. Consult Factory/MTU Onsite Energy Distributor for additional configurations.

APPLICATION DATA

// Engine

Manufacturer	MTU
Model**	6R1600G10F
Type	4-Cycle
Arrangement	Inline 6
Displacement: L (Cu In)	10.5 (641)
Bore: cm (in)	12.2 (4.8)
Stroke: cm (in)	15 (5.91)
Compression Ratio	17.5:1
Rated RPM	1,500
Engine Governor	ECU 8
Max Power: kWm (bhp)**	249 (334)
Speed Regulation	±0.25%
Air Cleaner	Dry

// Liquid Capacity (Lubrication)

Total Oil System: L (gal)	46 (12.2)
---------------------------	-----------

// Electrical

Electric Volts DC	24
Cold Cranking Amps Under -17.8 °C (0 °F)	1,000

// Fuel System

Fuel Supply Connection Size (in)	M 20x1.5 Male/#10 JIC Female
Fuel Return Connection Size (in)	M 14x1.5 Male/#6 JIC Female
Maximum Fuel Lift: m (ft)	5 (16)
Recommended Fuel	see MTU Fluids & Lubrication Spec.
Total Fuel Flow: L/hr (gal/hr)	171 (52.1)

** Prime technical data is for an Exhaust-Optimized Prime unit

// Fuel Consumption

		**PRIME
At 100% of Power Rating: L/hr (gal/hr)	63 (16.5)	
At 75% of Power Rating: L/hr (gal/hr)	48 (12.8)	
At 50% of Power Rating: L/hr (gal/hr)	34 (8.9)	

// Cooling - Radiator System

		**PRIME
Ambient Capacity of Radiator: °C (°F)	50 (122)	
Max. Restriction of Cooling Air, Intake, and Discharge Side of Rad.: kPa (in. H ₂ O)	0.2 (0.8)	
Water Pump Capacity: L/min (gpm)	277 (73.1)	
Heat Rejection to Coolant: kW (BTUM)	136 (7,734)	
Heat Rejection to After Cooler: kW (BTUM)	71 (4,037)	
Heat Radiated to Ambient: kW (BTUM)	14 (796)	
Engine Coolant Capacity: L (gal)	45 (11.9)	
Radiator Coolant Capacity: L (gal)	44 (11.6)	
Coolant to Cooler Temperature: °C (°F)	95 (203)	

// Air Requirements

		**PRIME
Aspirating: *m ³ /min (SCFM)	18 (635.7)	
Air Flow Required for Rad. Cooled Unit: *m ³ /min (SCFM)	372 (13,137)	
Remote Cooled Applications; Air Flow Required for Dissipation of Radiated Gen-set Heat for a Max of 25 °F Rise: *m ³ /min (SCFM)	46 (1,641.8)	

* Air density = 1.184 kg/m³ (0.0739 lbm/ft³)

// Exhaust System

		**PRIME
Gas Temp. (Stack): °C (°F)	485 (905)	
Gas Volume at Stack Temp: m ³ /min (CFM)	54 (1,907)	
Maximum Allowable Back Pressure: kPa (in. H ₂ O)	15 (60.2)	

WEIGHTS AND DIMENSIONS

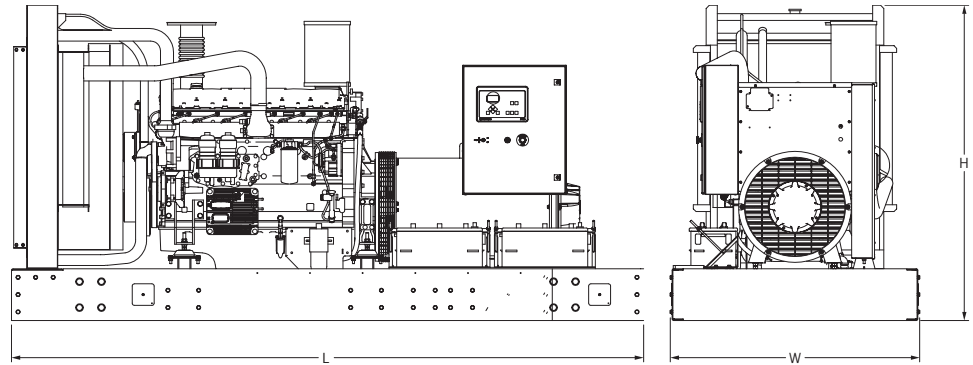

Drawing above for illustration purposes only, based on standard open power 400 volt engine-generator set. Lengths may vary with other voltages. Do not use for installation design. See website for unit specific template drawings.

System	Dimensions (L x W x H)	Weight (dry/less tank)
Open Power Unit (OPU)	3,658 x 1,445 x 1,855 mm (144 x 56.875 x 73 in)	3,078 kg (6,785 lb)

Weights and dimensions are based on open power units and are estimates only. Consult the factory for accurate weights and dimensions for your specific engine-generator set.

SOUND DATA

Unit Type	Prime Full Load
Level 0: Open Power Unit (dBA)	83.8

Sound data is provided at 7 m (23 ft). Engine-generator set tested in accordance with ISO 8528-10 and with infinite exhaust.

EMISSIONS DATA

NO _x + NMHC	CO	PM
C/F	C/F	C/F

RATING DEFINITIONS AND CONDITIONS

- // Prime power ratings apply to installations where utility power is unavailable or unreliable. At varying load, the number of generator set operating hours is unlimited. A 10% overload capacity is available for one hour in twelve. Ratings are in accordance with ISO 8528-1, ISO 3046-1, BS 5514, AS 2789, and DIN 6271.
- // Deration Factor:
 - Altitude:** Consult your local MTU Onsite Energy Distributor for altitude derations.
 - Temperature:** Consult your local MTU Onsite Energy Distributor for temperature derations.

Materials and specifications subject to change without notice.

C/F = Consult Factory/MTU Onsite Energy Distributor